

**BRACKET ATTACHMENT**  
 CONCRETE/MASONRY: POWERS WEDGE-BOLT, 3/8 X 1-3/4" LONG  
 STEEL: TYPE 23 HWH THD CUTTING SCREW, 3/8-16 X 1"

(\*) FOR PUSH-UP OPERATION: 4-1/8"  
 FOR HAND CHAIN OPERATION: 4-7/8"  
 FOR ELECTRIC OPERATION: 5-5/8"  
 FOR OUTSIDE OF CHAIN DRIVE: 6-3/8"  
 NOTE: RIGHT SIDE DRIVE SHOWN

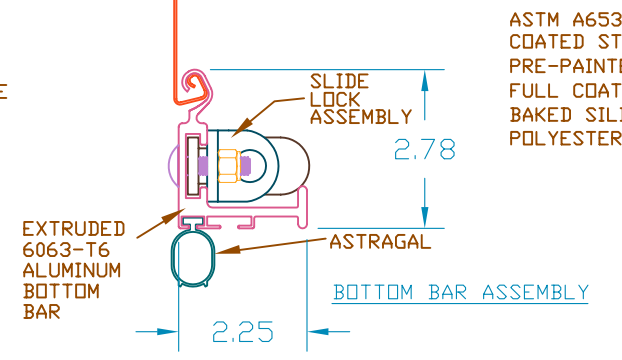

REVISIONS			
REV	DESCRIPTION	DATE	APPROVAL
-	DRAWING RELEASE	5-9-08	DM

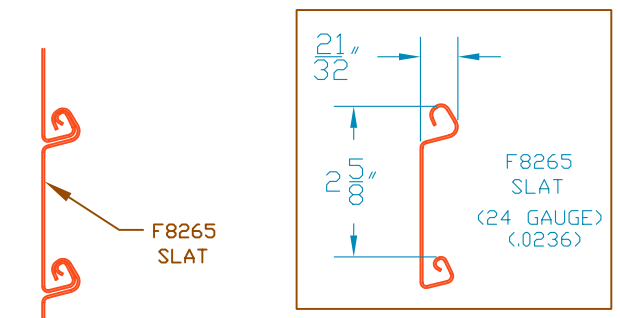
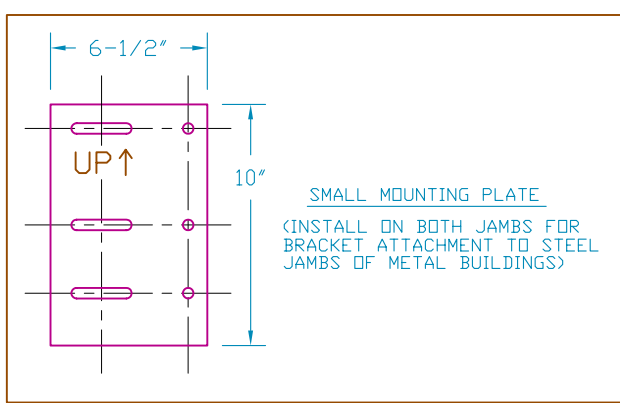
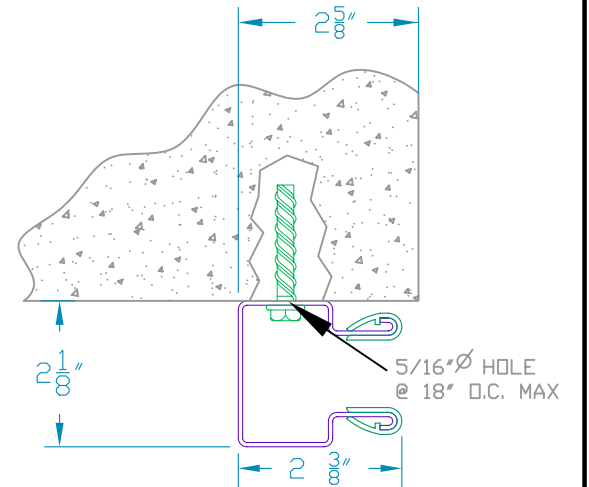

CONCRETE/FILLED BLOCK JAMBS  
 USING 1/4" X 1-3/4" POWERS WEDGE-BOLT

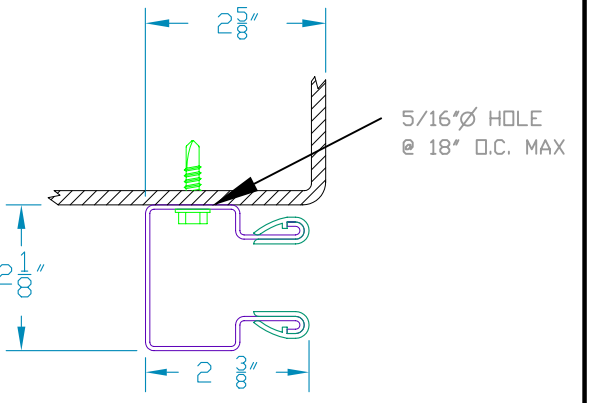

STEEL JAMBS  
 USING 1/4-14 X 1" TEKS

16 GA (.063) GUIDE MOUNTING DETAIL

ALL COMPONENTS SHALL BE  
 ASTM A653 STEEL W/MIN  
 FY=33 KSI GALVANIZED  
 PER ASTM A653 G-90

SIDE VIEW

INSIDE ELEVATION

SEE SHEET 2 FOR NOTES

HEADROOM REQUIRED		
OPENING HEIGHT	VERTICAL HEADROOM	HORIZONTAL HEADROOM
THRU 8'-0"	17'	19'
OVER 8'-0" THRU 10'-0"	19'	21'
OVER 10'-0" THRU 14'-0"	20'	22'
OVER 14'-0" THRU 16'-0"	21'	23'
OVER 16'-0" THRU 18'-0"	22'	24'
OVER 18'-0" THRU 20'-0"	23'	25'

ALLOWABLE TRANSVERSE DESIGN WIND LOADS (PSF)		
MAX DOOR WIDTH	MAX DOOR HEIGHT (FT)	DESIGN WIND LOADS (PSF)
6'-4"	20	+28.3/-33.6
7'-4"	20	+24.4/-29.1
8'-4"	20	+21.5/-25.6
9'-4"	20	+19.2/-22.9
10'-4"	20	+17.4/-20.7

THESE CONFIDENTIAL DOCUMENTS SUBMITTED BY JANUS CONTAIN INFORMATION OF A PROPRIETARY NATURE AND MAY NOT BE REPRODUCED OR USED TO MANUFACTURE ANYTHING IN PART OR IN WHOLE FOR ANY PURPOSE OTHER THAN THAT WHICH IS NECESSARY FOR PREPARATION OF BIDS OF ENGINEERING WITHOUT THE EXPRESS PERMISSION OF JANUS WHICH MAY RECALL DOCUMENTS AT ANY TIME.

UNLESS OTHERWISE SPECIFIED DIMENSIONS ARE IN INCHES AND TOLERANCES ARE:

DECIMAL	FRACTIONS	ANGLES	HOLE DIAMETERS
.XX ±.03	± 1/16	± 0° 30'	UNDER .251 +.004 -.003
.XXX ±.005			.251 to .500 +.006 -.003
			OVER .500 +.008 -.003

PART NUMBER:	NA
MATERIAL:	NA
APPLIED FINISH:	NA
UNIT OF MEASURE:	NA
APPROVALS	DATE
DRAWN:	CINDY WOOTEN 5-9-08
CHECKED:	DON MILLS 5-9-08
APPROVED:	DON MILLS 5-9-08

Amarr Garage Doors Model 5700/5701	
<b>CERTIFIED WIND LOAD RATED SERIES MD16 DOOR ASSEMBLY MAX. SIZE 10'-4" X 20'-0"</b>	
SIZE	DRAWING NUMBER: RS9000
SCALE: NONE	SHEET: 1 OF 2

REVISIONS			
REV	DESCRIPTION	DATE	APPROVAL
-	DRAWING RELEASE	5-9-08	DM

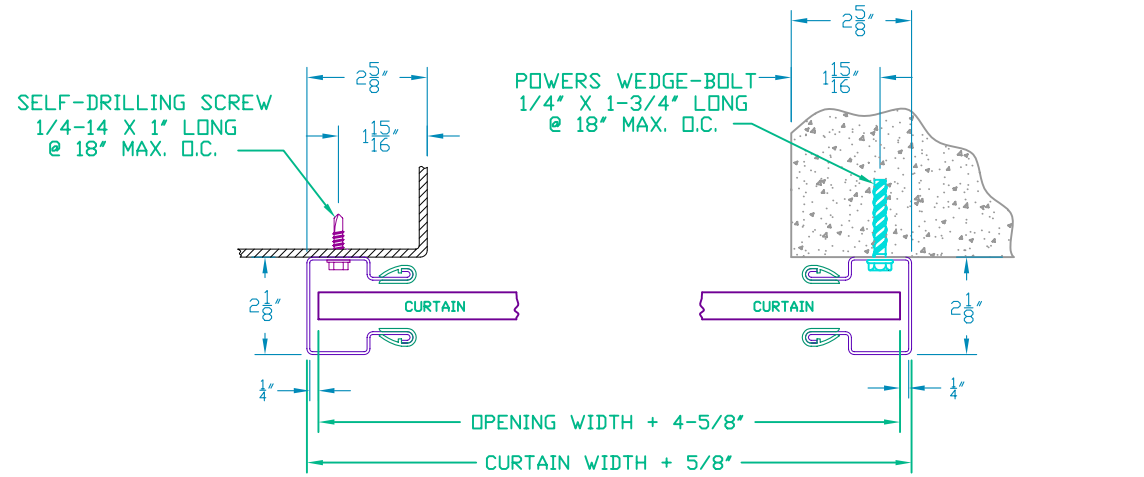

STEEL JAMBS  
LH GUIDE MOUNT SHOWN

CONC/FILLED BLOCK JAMBS  
RH GUIDE MOUNT SHOWN

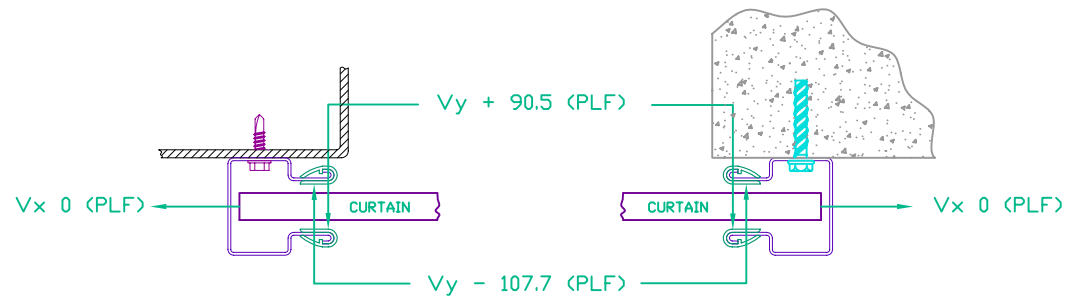

STEEL JAMBS  
LH GUIDE MOUNT SHOWN

CONCRETE/FILLED BLOCK JAMBS  
RH GUIDE MOUNT SHOWN

SUPERIMPOSED LOAD DIAGRAM

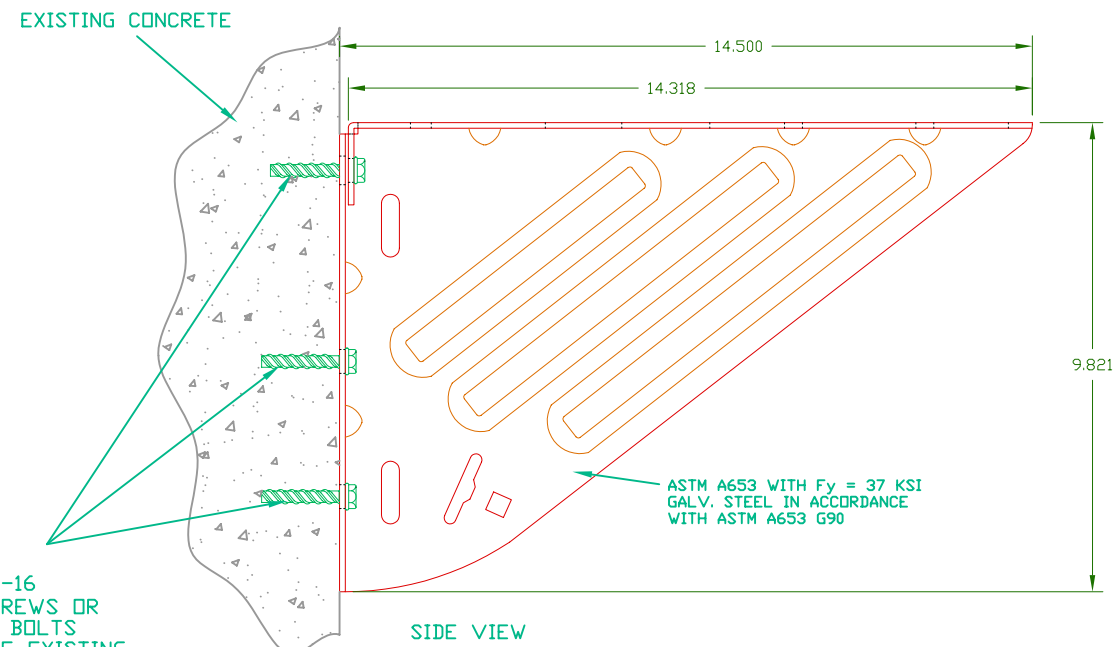

SIDE VIEW

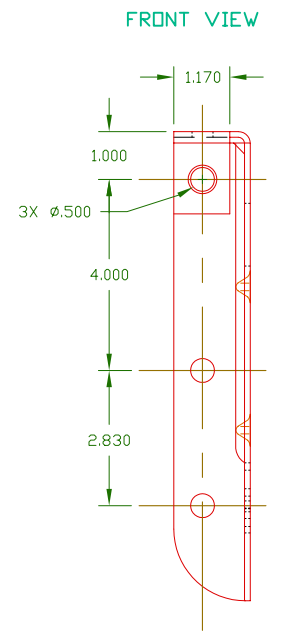

FRONT VIEW

THREE 3/8"Ø POWERS WEDGE-BOLTS W/ 1-1/2" MIN. EMBEDMENT IN CONCRETE OR THREE 3/8-16 HWH THREAD CUTTING SCREWS OR THREE 3/8" STEEL THRU BOLTS INTO MIN. 1/8" STEEL. IF EXISTING IS MASONRY, FILL CELL W/2500 PSI GROUT.

ASTM A653 WITH Fy = 37 KSI GALV. STEEL IN ACCORDANCE WITH ASTM A653 G90

DOOR MOUNTING BRACKET DETAIL

GENERAL NOTES

- THIS ROLLING DOOR SYSTEM IS DESIGNED IN ACCORDANCE WITH ASCE 7-02, 2007 FBC AND INTERNATIONAL BUILDING CODE 2006.
- THIS ROLLING DOOR HAS BEEN TESTED IN ACCORDANCE WITH ASTM E-330 AND ANSI/DASMA 108 TO SAFELY RESIST A POSITIVE OR NEGATIVE WIND LOAD AS NOTED BELOW. A TEST LOAD OF 1.5 X DESIGN LOAD HAS BEEN USED.  
  
DESIGN LOAD = +17.4 PSF  
-20.7
- WIND LOADS FOR BUILDING OPENINGS SHALL BE DETERMINED BY A PROFESSIONAL ENGINEER USING APPROPRIATE WIND SPEED AND DESIGN CRITERIA. THIS DOOR MAY BE USED WHERE THE DESIGN LOAD MEETS OR EXCEEDS THE DESIGN LOAD FOR THE BUILDING OPENING.
- SUPERIMPOSED LOADS ON THE JAMBS FROM THIS DOOR ARE DESIGNED AS Vx AND Vy HEREIN. CONTRACTORS SHALL HAVE BUILDING ENGINEER VERIFY ADEQUACY OF BUILDING STRUCTURE TO RESIST SUPERIMPOSED LOADS Vx, Vy AND BRACKET LOADS SHOWN.
- ALL WELDING SHALL BE PERFORMED BY QUALIFIED WELDERS IN ACCORDANCE WITH A.W.S. SPECIFICATIONS, LATEST EDITION. ALL WELDING ELECTRODES SHALL CONFORM TO A.W.S. A5.1 GRADE E-70.
- DOORS SHALL BE PROVIDED WITH LOCK MECHANISMS LOCATED AT BOTH ENDS OF THE BOTTOM BAR.
- ALL BOLTS AND WASHERS SHALL BE GALVANIZED OR STAINLESS STEEL WITH A MINIMUM TENSILE STRENGTH OF 60 KSI.

- DESIGN BASED ON CERTIFIED TESTING LABORATORIES, INC., TEST REPORT NO. CTLA-1837W.
- ANCHOR NOTES:  
A. EMBEDMENT LENGTH DOES NOT INCLUDE STUCCO FINISH.  
B. FOR HOLLOW MASONRY, FILL ALL CELLS @ ANCHOR WITH 2500 PSI GROUT.  
C. ANCHORS SHALL BE INSTALLED IN ACCORDANCE WITH MANUFACTURER'S SPECIFICATIONS.
- DOOR OPERATION TYPE TO BE PUSH-UP, HAND CHAIN, HAND CRANK OR ELECTRIC.

- GUIDE TO JAMB ATTACHMENT FASTENERS BEGIN 4" FROM FLOOR AND END 3-1/2" BELOW TOP OF WALL OPENING.
- TEST DOOR WALL OPENING SIZE: 10'-4" x 10'-0".

THESE CONFIDENTIAL DOCUMENTS SUBMITTED BY JANUS CONTAIN INFORMATION OF A PROPRIETARY NATURE AND MAY NOT BE REPRODUCED OR USED TO MANUFACTURE ANYTHING IN PART OR IN WHOLE FOR ANY PURPOSE OTHER THAN THAT WHICH IS NECESSARY FOR PREPARATION OF BIDS OF ENGINEERING WITHOUT THE EXPRESS PERMISSION OF JANUS WHICH MAY RECALL DOCUMENTS AT ANY TIME.

UNLESS OTHERWISE SPECIFIED DIMENSIONS ARE IN INCHES AND TOLERANCES ARE:

DECIMAL	FRACTIONS	ANGLES	HOLE DIAMETERS
.XX ±.03	± 1/16	± 0° 30'	UNDER .251 +.004 -.003
.XXX ±.005			.251 to .500 +.006 -.003
			OVER .500 +.008 -.003

PART NUMBER:	NA	Amarr Garage Doors Model 5700/5701			
MATERIAL:	NA				
APPLIED FINISH:	NA				
UNIT OF MEASURE:	NA				
APPROVALS:	DATE:	CERTIFIED WIND LOAD RATED SERIES MD16 DOOR ASSEMBLY MAX. SIZE 10'-4" X 20'-0"			
DRAWN:	CINDY WOOTEN		5-9-08		
CHECKED:	DON MILLS		5-9-08		
APPROVED:	DON MILLS	5-9-08	SIZE: B	DRAWING NUMBER: RS9000	REV: —
SCALE: NONE		SHEET: 2	OF: 2		